

metalphoto[®]

Cross-section

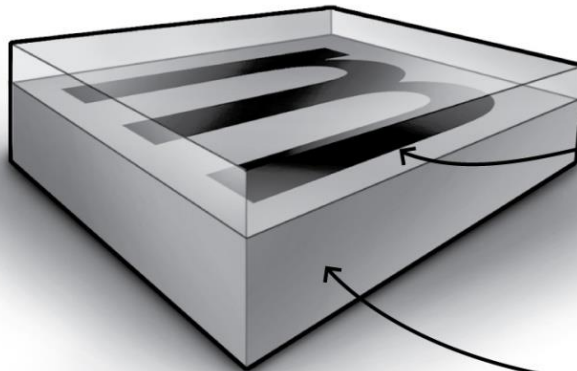

anodic layer

the glass-clear, sapphire-hard anodized layer resists chemicals, paint, abrasion and dirt.

sealed image

black graphics are metallic silver particles that hold up to extreme heat and sunlight exposure.

aluminum layer

the rigid aluminum base will not peel, crack or delaminate.

Agenda

- What is Metalphoto[®] and why is it so special?
- When & Where to use (and not use) Metalphoto[®]?
- How Metalphoto[®] is sold around the world?
- Tools to sell it...





What is Metalphoto?

And why is it so special?

What Is Metalphoto[®]?

- Developed in 1950 by Horizons Incorporated for a Navy research grant.
- Not just a brand name, “photosensitive anodized aluminum” (generic name for Metalphoto) is a unique engineered material made by one company in the world – US! (https://en.wikipedia.org/wiki/Photosensitive_anodized_aluminum)
- Trusted for over 70 years by many of the biggest OEMs, military and government organizations to identify their products and/or track their assets because of its unique combination of **durability**, **graphic capability**, **variable data capability** and **long history of proven performance**.



DURABILITY



IMAGE
RESOLUTION



PROVEN
PERFORMANCE



VARIABLE
INFO

What Is Metalphoto[®]? (cont.)

- Metalphoto's durability comes from its inorganic silver-halide image, which is sealed *inside* of the anodized aluminum layer, providing extreme resistance to a wide variety of environmental/operational degradation threats.
- DISUCSS MANUFACTURING PROCESS (SECRETE)

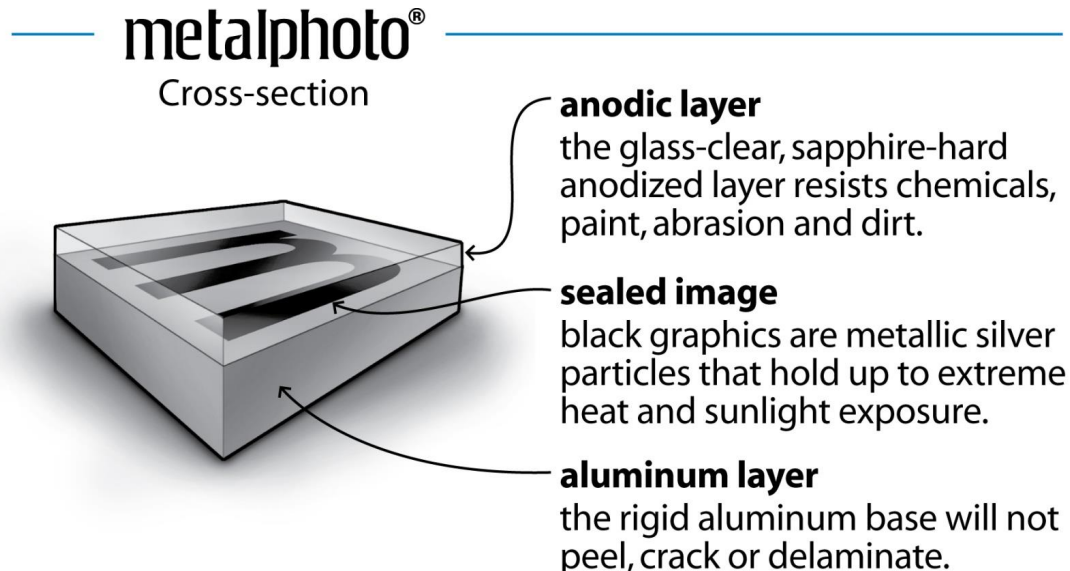

Durable Construction Means...



- Because of Metalphoto's strong resistance to a wide variety environmental factors, it is a good choice in specific applications or cases where the actual operating conditions are variable or unknown.



Weather/UV Resistance

- 20+ years outdoor life...
- Prolonged Sun Exposure in Desert, Marine or Tropical Environments
- Moisture, Rain & Snow



Abrasion Resistance

- Blowing Sand
- Grit/Dirt
- High Velocity Impact
- Pressure Washing
- Operator Abuse



Temperature Resistance

- Desert ~ 130°F
- Engine ~ 220°F
- Weapons ~ 160°F
- Sterilization ~ 270°F
- Ultra High Temp ~ 1,000°F



Corrosion Resistance

- Saltwater emersion
- Salt spray exposure
- Salt fog exposure



Chemical Resistance

- Hydraulic Fluid
- Jet Fuel
- Cleaning Solvents (MEK)
- Alkaline Cleaners
- Acetic Acid

*More top scores than any other label material tested by the U.S. Navy
(NSWC, Corona Division, IUID Center; August 2011).*

Durable Construction Means...



METALPHOTO® DURABILITY CHARACTERISTICS

SPECIFIC CHARACTERISTIC	TEST CONDITION	EFFECT
Exterior Exposure	Black and silver image exceeds 400 hr. Weatherometer Test GG-P-455b, estimated equivalent to 20 yr. exposure	No effect
Abrasion Resistance	Taber Abraser with CS17 wheel, a total of 1000 gm. load, 7000 cycles	Slight dulling of surface
Temperature Resistance	Black & silver image, intensified, 1000°F Black & silver image, standard, 750°F	Slight dulling Slight dulling
Salt Spray	5% at 95°F for 700 hrs.	No corrosion
Chemical Resistance		
MIL-S-3136 III Hydrocarbon Fluid	1 hr. immersion	No effect
MIL-L-5161C-Turbine and jet engine fuel	1 hr. immersion	No effect
JP-4 fuel	72 hr. immersion	No effect
Kerosene	12 hr. immersion	No effect
Skydrol (Hydraulic Fluid)	24 hr. immersion, at both room temperature and boiling point	No effect
Methyl Ethyl Ketone (MEK)	24 hr. immersion	No effect
Ethyl Acetate	24 hr. immersion	No effect
Xylol	72 hr. immersion	No effect
Heptane	72 hr. immersion	No effect
Ethyl Alcohol	72 hr. immersion	No effect
Ferric Chloride	10% solution, 16 hr. immersion	No effect
Ammonium Hydroxide	10% solution, 16 hr. immersion	Slight dulling
MIL-P-21563 soap solution	16 hr. immersion	No effect
MIL-C-25179 AIN in heptane	25% solution, 1 min. immersion (cleaning solution)	No effect
Sulfuric Acid	10% solution, 24 hr. immersion	No effect
Phosphoric Acid	1% solution, 12 hr. immersion	No effect
Nitric Acid	3% solution, 72 hr. immersion	No effect
TSP (Trisodium Phosphate)	1% solution, 40 hr. immersion	No effect

METALPHOTO PRODUCT SPECIFICATIONS

SPECIFICATION	PUBLICATION	DETAIL	DESCRIPTION
GG-P-455b	Federal Specification	Type I, Grade A or B Classes 1 & 2	Photosensitive anodized aluminum impregnated with silver compounds printable on one or two sides – all finishes and thicknesses.
MIL-P-15024D	Military Specification	Type H & G	Totally anodized aluminum with characters integrated into the anodized layer photographically using silver compounds.
MIL-P-19834B	Military Specification	Type I or II, Style III or IV	Metalphoto .003" thick plates with the proper adhesive applied meets or exceeds all of the performance requirements of this spec.
MIL-P-514D	Military Specification	Composition C	Photosensitive aluminum plates, grade and class as specified in federal specification GG-P-455b.
Industrial – Commercial Products	Original Equipment Panel Fronts Nameplates	Metalphoto products	Material shall be Metalphoto. Image (black on silver or silver on black) shall be sealed into the anodized layer with photosensitive silver compounds; colors other than black may be imbedded by resist or screen process.

*Metalphoto is a registered trademark of Horizons Research Incorporated.

DS2 - 5/87

METALPHOTO

A DIVISION OF HORIZONS RESEARCH INCORPORATED
18531 South Miles Road, Cleveland, Ohio 44128
1-800-482-7758 · In Ohio: (216) 475-0555

Metalphoto on Fire

□ USS Constellation (CVA-64)

- Keel Laid: September 14, 1957
- Launched: October 8, 1960
- Commissioned: October 27, 1961
- Decommissioned: August 7, 2003



Variable Data Capability Means



- Metalphoto “likes” durable, variable data applications – each plate contains different graphic info.



- **Why machine-readable barcodes?** - unique barcodes connect assets with unlimited item-specific data in the cloud:

- Serial number & cage code
- Usage history
- Maintenance history
- Location
- Value
- Possession

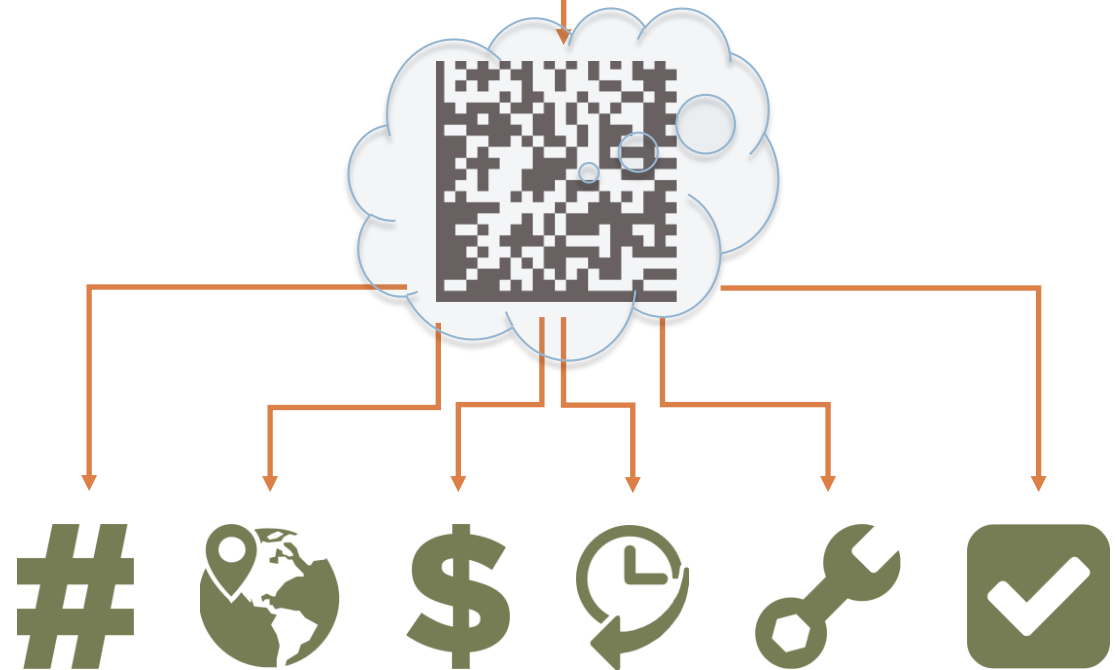

Metalphoto for Freedom?



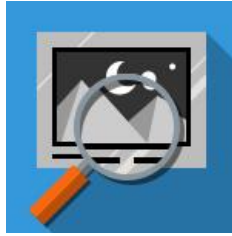

Photographic Resolution Means...

- The Metalphoto image can achieve extremely small sizes – 0.5 point font and images at a resolution of 2540 DPI, dots per inch.
- Benefit is Metalphoto's photographic resolution capability can be used produce small, high-resolution labels to identify small items or surfaces where a large label is not feasible.
- Metalphoto's resolution supports security printing features such as micro-print and watermarks that verify authenticity, protect against counterfeiting.



<https://www.camcode.com/security-labels/>

Metalphoto for Health?

metalphoto®

Metalphoto® White Paper: Medical Device Identification

Metalphoto® photosensitive anodized aluminum is proven to withstand multiple sterilization cycles and not fade or harbor bacteria as per ANSI/AAMI ST79 steam sterilization and sterility assurance.

Why Identify Medical Devices and Hospital Procedures?

Healthcare providers label and identify property and processes in order to keep track of inventory, communicate hospital procedures and manage recalls. Items that must undergo sterilization or other cleaning procedures are especially difficult to label. The sterilization process can degrade plastic or printed materials, rendering these labels and signs illegible. The cost of illegible labels is greater for medical devices and sterilization containers, where the inability to survive the sterilization process can lead to lost inventory and medical errors.



Illegible labels on medical devices can lead to inefficiencies and safety hazards.



Metalphoto in Space?

SAE TECHNICAL
PAPER SERIES

2000-01-2437

Special Requirements for Crew Interface Labels on the International Space Station

Stephen F. Gray and Fernando Ramos
Boeing

External Labels

Label materials for external use were one of the early challenges facing label designers for the long-duration mission of ISS. The flight crew integration standard required labels to meet the same functional life requirements as the equipment they were mounted on or associated with. That ensured that inks, pigments and other organic materials could not be used for external labels because of environmental life limits caused by Atomic Oxygen, a corrosive element existing in ISS orbits. This environmental effect limited available colors, adhesives and protective materials and shielding. An example of a material that was limited in use by the environment is clear Teflon, originally thought to be a promising material for protecting pigmented labels. Clear Teflon becomes opaque when exposed to the orbital environment. Although it would protect the label, it also would prevent viewing of it. This doesn't investigate the technical and scientific details of these material problems, but will note their limiting effects on label material choices and ultimately on the visual cues that external labels could provide. As noted in the discussion of internal labels, color is an important part of visual communication, particularly in safety-related information. Yellow and red are commonly used for cautions and warnings. Material designers determined that a gold anodize could be produced for EVA handrails that were normally yellow on other space craft. This same gold anodized material could be used as a

substitute for yellow on warning labels. A red material was found to meet environmental life requirements for labels although it did not match the SMSJ spectral requirements for red safety labeling. Because the costs of producing a useable red were high, the program accepted a reduced dependence on red as a cue in certain types of external labels such as those that point to the Airlock. Those Airlock labels became part of the location coding requirements

The most useful material that was found to meet the long-life requirements for external labeling in harsh environments was a photosensitive aluminum foil (Metalphoto or its equivalent) that provided black (photographically exposed) characters, symbols and borders on a silver white (unexposed aluminum) background. The foils specified by Boeing Huntington Beach were available in hardened aluminum (H18) with matte finish in the following thickness (5, 8, 20 and 32 mil) and an annealed, dead soft aluminum with satin finish in a 5-mil thickness. Most labels attached to hard surfaces were the 5 mil thickness, while labels tied to cables and soft surfaces such as insulation were 20 mil thickness. The thicker material was used on soft material because the thicker edge could be rounded to eliminate sharp edge hazards, that were not a risk when the 5 mil labels were securely attached with adhesive to hard surfaces.

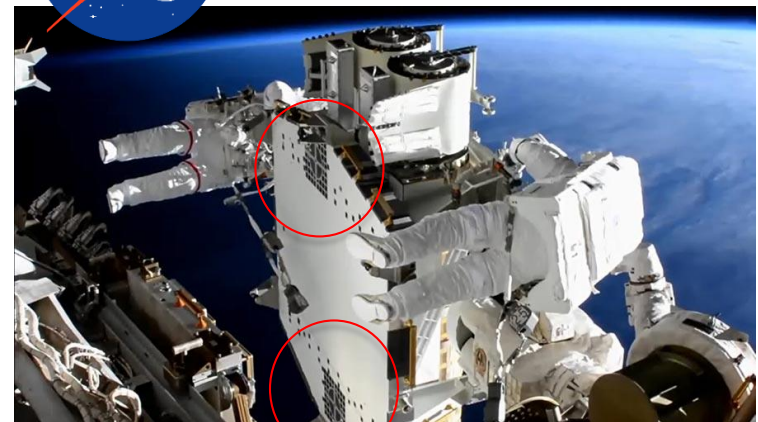
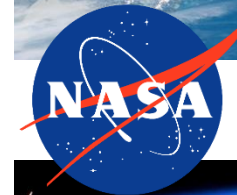
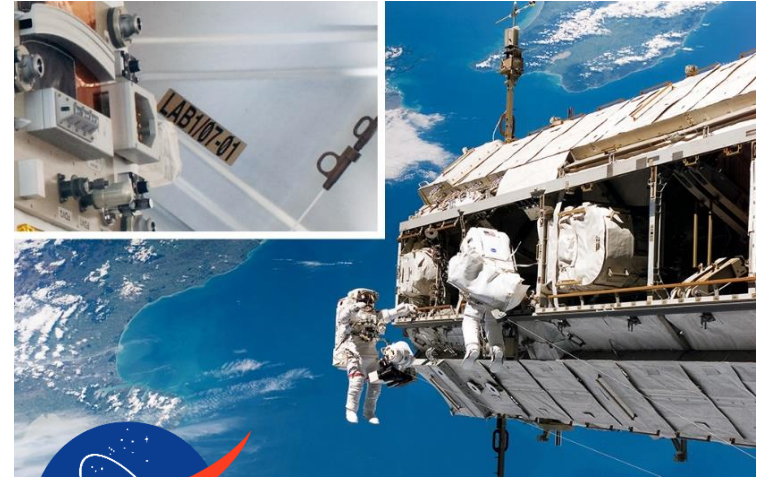

SAE The Engineering Society
For Advancing Mobility
Land Sea Air and Space
INTERNATIONAL

on environmental by
Toulouse, France
July 10-13, 2000

400 Commonwealth Drive, Warrendale, PA 15096-0001 U. S. A. Tel: (724) 776-4841 Fax: (724) 776-5760



Proven Performance Means...

Independent Performance Tests

- [IUID Environmental Survivability Testing Report](#)
- [AAMI/CDV-1 ST79:2010/A2.06 Steam Sterilization Validation](#)
- [A-A-50271 \(~MIL-P-514D\) Certification to Specification](#)
- [FieldQR Label Testing Tech Bulletin](#)
- [Corrosion Test of Anodized Aluminum Plates – Metalphoto](#)
- [Laboratory Evaluation of Label Plate Materials and Attachment Methods Considered for Use on LPD-17](#)
- [Special Requirements for Crew Interface Labels on the International Space Station](#)
- [Tests of Metalphoto for Mil-STD-15024](#)
- [Accelerated Oxygen Aging and Accelerated Light and Weather Resistance of Metalphoto Adhesive Backed Identification Plates](#)

Independent Certifications/Specifications

- BF Goodrich Aerospace
- Boeing Commercial Aircraft Company
- Honeywell, Inc.
- SAE
- ASTM B209
- Federal Specification GGP-455B
- MIL-A-8625F
- MIL-DTL-15024F
- MIL-STD-130N
- MIL-P-19834B
- CARDIVNSWC-TR-62-00-05 June 2000
- Space Station Inventory Label Specification - SSP 50007
- A-A-50271 Class 2- Composition C

Internal Testing & Certifications

- [Metalphoto Data Sheet](#)
- [Metalphoto Foil Spec Sheet](#)
- [Metalphoto with Teflon Spec Sheet](#)
- [Metalphoto Extra High Temperature \(XHT\) Spec Sheet](#)
- **Comparisons**
- [Metalphoto vs. Etched Stainless Steel](#)
- [Horizons Material Comparison](#)
- **Demonstrations**
- [Will It Read Destructive Testing PowerPoint](#)
- [Will It Read Testing Video \(Abrasion\)](#)
- [Will It Read Testing Video \(High Temp\)](#)
- [Will It Read Testing Video \(Saltwater\)](#)
- [Will It Read Testing Video \(Chemical Exposure\)](#)
- **Guides**
- [Metalphoto Attachment Guide](#)
- [IUID Marking Pilot Program](#)

metalphoto®

LOCKHEED MARTIN



Honeywell

BOEING®

Metalphoto for Inspection & Maintenance Automation?



Read me...I'm the fed spec for MP!

GGP – 455B

Where to use Metalphoto[®]?

And not use...

When To Recommend Metalphoto?

- **By condition/environment:** 20yrs+ life expectancy; high heat, abrasion, chemical, marine/saltwater exposure...
- **By specification/certification:** GGP-455B, MIL-DTL-15024F, MIL-STD-130, MIL-P-19834B, A-A-50271, MIL-DTL-19834C, MIL-P-6906B, MIL-A-8625F, SAE-AMS-QQ-A-250/1 or simply call outs for “photosensitive anodized aluminum”.
- **By graphic requirement:** durability and variable data in the form of barcodes, QR codes and/or item unique instructions/data or security printing/anti-counterfeit.
- **By application:** military, aerospace, marine, transportation, heavy equipment, etc.
- **Or ... WHEN OTHER MATERIALS FAIL!**

Metalphoto for Ocean/Saltwater?

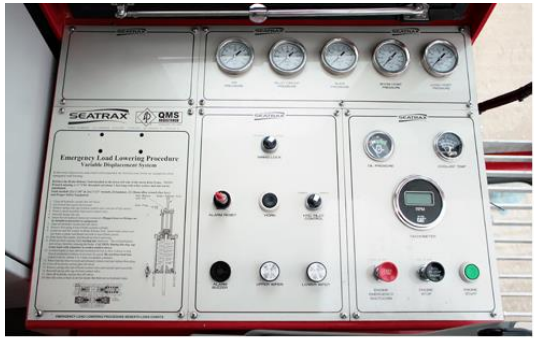

Norwegian Marine Technology Research Institute A/S
 MAIN OFFICE: Otto Nielsens vegg 10, P.O.Box 4125 Valentinslyst, N-7002 Trondheim, Norway
 Tel.: +47-7 59 55 00, Telex: 55146 marit n, Telefax: +47-7 59 57 76
 SANDEFJORD: P.O.Box 173 Annes, N-3201 Sandefjord, Norway
 Tel.: +47-34-73 033

File no.	
Report no. 23.1011.00.03.91	
Accessibility	
No. of pages	Model no.

Report title: Corrosion test of anodized Al-name plates - Metalphoto	
Commission/project title:	
Client: Åge Børresen Stempelfabrikk A/S Hågasletta 11 3200 SANDEFJORD	Client's ref.: Åge Børresen Hans Kai Kristoffersen
Commission/project manager: Sofie Skjerve Helge Moving	Work carried out by: Kaare O Kristiansen, Kåre Malberg, Helge Moving
External cooperation with:	Represented by:

Summary of the report:

Corrosion testing of 43 anodized aluminium name plates has been performed. The name plates have been exposed to **natural seawater** under various exposure conditions and in a salt spray chamber. **In general very good corrosion resistance was demonstrated.** The present report is a translated version of the original report issued in Norwegian (see below). The translation has been done by Adamant Märk system. The translated version has been approved by MARINTEK (August 1991).

Other documentation:

- 23.1011.00.01.91 Korrosjonsprøving av elokserte Al-skilt
- 23.1011.00.02.91 Korrosjonsprøving av elokserte Al-skilt, **Metalphoto**

Subject words: Korrosjon
(in Norwegian) Elokserte Al-skilt
 Sjøvann
 Salttåke

City/date: Sandefjord, 120891

 Reported by
 Project manager/Head of department

Unsure?

- Horizons Incorporated does not warranty the performance of its products in ANY environment.
- Users must test products in the environment in which they are expected to function.
- We will certify our specs and our cert...
- Or ask us to help...

METALPHOTO® DURABILITY CHARACTERISTICS		
SPECIFIC CHARACTERISTIC	TEST CONDITION	EFFECT
Exterior Exposure	Black and silver image exceeds 400 hr. Weatherometer Test GG-P-455b, estimated equivalent to 20 yr. exposure	No effect
Abrasion Resistance	Taber Abraser with CS17 wheel, a total of 1000 gm. load, 7000 cycles	Slight dulling of surface
Temperature Resistance	Black & silver image, intensified, 1000°F Black & silver image, standard, 750°F	Slight dulling Slight dulling
Salt Spray	5% at 95°F for 700 hrs.	No corrosion
Chemical Resistance		
MIL-S-3136 III Hydrocarbon Fluid	1 hr. immersion	No effect
MIL-L-5161C-Turbine and jet engine fuel	1 hr. immersion	No effect
JP-4 fuel	72 hr. immersion	No effect
Kerosene	12 hr. immersion	No effect
Skydrol (Hydraulic Fluid)	24 hr. immersion, at b	
Methyl Ethyl Ketone (MEK)	24 hr. immersion	
Ethyl Acetate	24 hr. immersion	
Xylol	72 hr. immersion	
Heptane	72 hr. immersion	
Ethyl Alcohol	72 hr. immersion	
Ferric Chloride	10% solution, 16 hr. im	
Ammonium Hydroxide	10% solution, 16 hr. im	
MIL-P-215G3 soap solution	16 hr. immersion	
MIL-C-25179 AIN in heptane	25% solution, 1 min. im	
Sulfuric Acid	10% solution, 24 hr. im	
Phosphoric Acid	1% solution, 12 hr. im	
Nitric Acid	3% solution, 72 hr. im	
TSP (Trisodium Phosphate)	1% solution, 40 hr. im	
METALPHOTO PRODUCT SPECIFICATIONS		
SPECIFICATION	PUBLICATION	DETAIL
GG-P-455b	Federal Specification	Type I, Grade A or B Classes 1 & 2
MIL-P-15024D	Military Specification	Type H & G
MIL-P-19834B	Military Specification	Type I or II Style III or IV
MIL-P-514D	Military Specification	Composition C
Industrial - Commercial Products	Original Equipment Panel Fronts Nameplates	Metalphoto products

*Metalphoto is a registered trademark of Horizons Research Incorporated.

METALPHOTO
A DIVISION OF HORIZONS RESEARCH
18531 South Miles Road, Cleveland, OH 44128
1-800-482-7758 - In OH

ISG Imaging Systems Group
CERTIFICATE OF COMPLIANCE

To: Camcode Warehouse 18531 South Miles Road Cleveland, OH 44128 USA Ship Date: 03Oct2022

Order Number: ccPOC106180
Pack Slip: PS148872
PO Date: 24May2022
PO Number: Camcode Warehouse # POC106180

Item #	Qty	Item Group	Item Description	Temper	Lot #	DOM	See
03134	20	Metalphoto 1	MPI-020-12x20 Satin (75)	H-18	1763	29Sep2022	A,B,D,J,L

A This is to certify that the above listed product is manufactured and tested to comply with manufacturing process controls as established by the Horizons Imaging Systems Group (ISG).

All ISG products and solutions are lot tracked to date of manufacture with traceability to the original raw materials. Lot number and date of manufacture (DOM) are printed upon each product package label.

Adhesives sold in rolls have a shelf life of 18 months from the time of shipment to Horizons, Inc., when stored at room temperature conditions of 72°F & 50% relative humidity. Storage in plastic bag is recommended. Be advised that the adhesive manufacturer notes that the shelf life is intended for the storage of the unconverted product only. The manufacturer does not provide a shelf life recommendation for the final application such as labels and nameplates when to apply the final adhesive laminated part is left to the discretion of the end user.

The 3M pressure sensitive adhesive products conform to the requirements of MIL-DTL-19834C, Type I.

All products and solutions (except as noted below) have a minimum shelf life or storage life of one (1) year from ship date when unopened and in original packaging.

EconAlum aluminum plates have a shelf life of two years from ship date, when stored in their original, unopened package in a room maintained at a temperature of 68 ±2°F and at a relative humidity of 50 ±2% only.

NOTE: Materials must be stored at 68 -72°F unless otherwise noted.

B Metalphoto Certification:
When processed in accordance with ISG's instructions, the Metalphoto photosensitive anodized

metalphoto • DURABLACK • ALUMAMark • ALUMAJet • ID-MARK

18531 South Miles Road • Cleveland, Ohio 44128 • phone 800.482.7758 • fax 216.475.6507
www.horizonsisg.com • info@horizonsisg.com

Metalphoto for Aircraft?

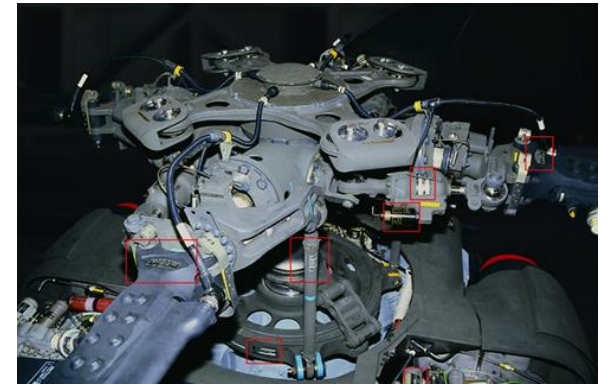

J:\Corporate\Specifications & Compliance



How you can get Metalphoto parts?

- How ISG goes to market (converter vs. distributor)
- Make vs. Buy (pre-print vs. system)
- Rough system cost/how sold
- Fakers - how to address?
- Competitors - how to address?

Horizons Distribution Model/GTM

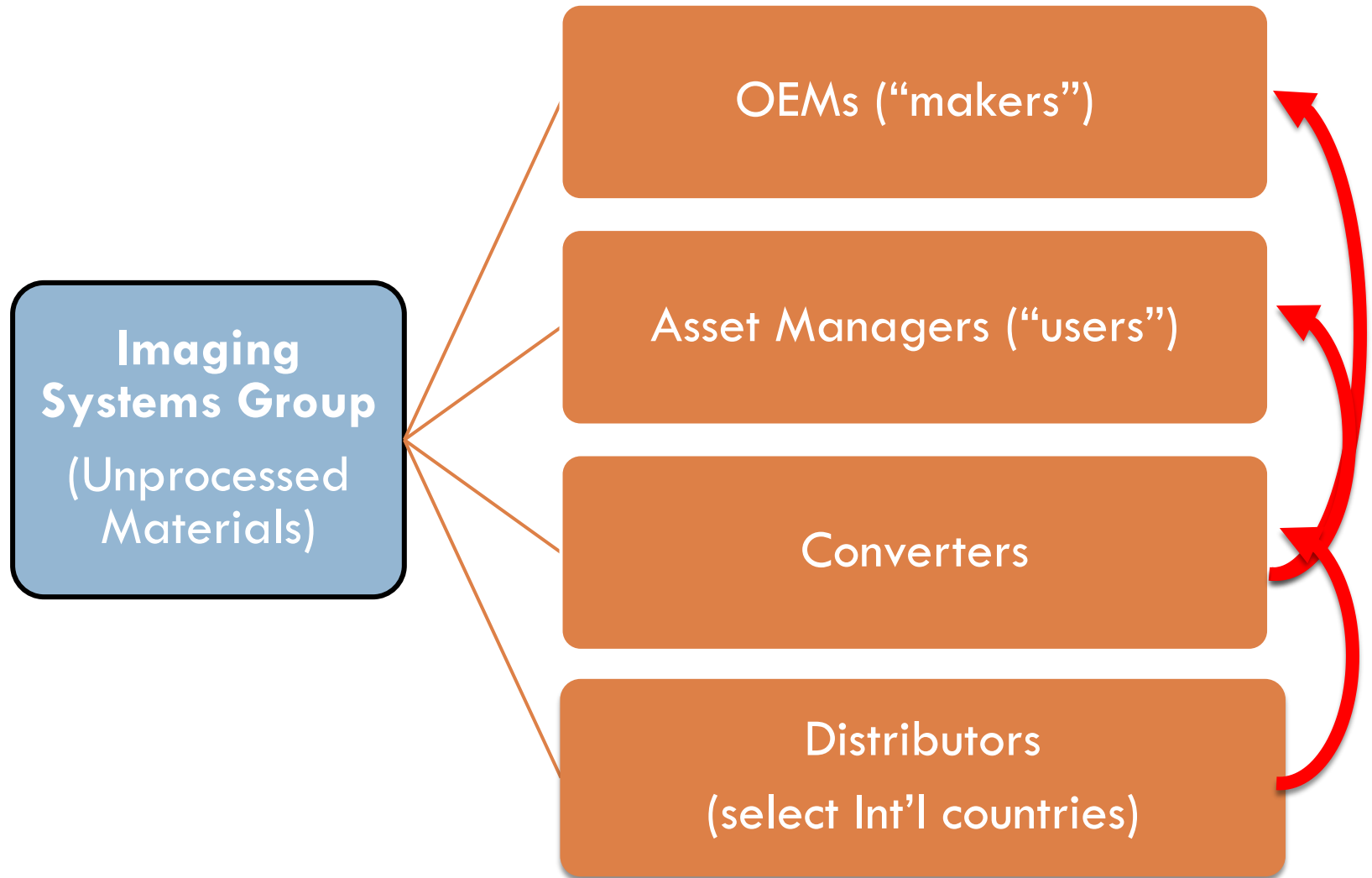

Make vs. Buy (according to a pre-print salesman)



Making labels



Buying Labels

True Cost of Onsite Production

metalphoto



ON-SITE PROCESSING



**Nameplates /
Barcode Labels**



**Service Diagrams /
Schematics**



**Machine
Control Panels**

THE TECHNOLOGY:

ANODIZED LAYER
The glass-clear, scratch-resistant anodized layer resists chemicals, paint, abrasion and dirt.



SEALED IMAGE ALUMINUM LAYER
The rigid aluminum base won't peel, crack or delaminate. The image is absorbed into the pores.



**EXCEPTIONALLY DURABLE.
WIDELY SPECIFIED.
HIGH RESOLUTION GRAPHICS.**

WHY PRODUCE METALPHOTO ON-SITE?

Metalphoto can be produced at your location where and when needed or purchased from worldwide network of approved suppliers. Many companies choose to process Metalphoto at their own facility. Some of the reasons to produce Metalphoto on-site are:

<p>ECONOMICS MORE COST EFFICIENT FOR BUDGETS, SALES AND PROFIT</p> 	<p>SECURITY CONTROL OVER YOUR SENSITIVE PROPRIETARY DATA</p> 	<p>AVAILABILITY CONTROL OVER THE PRODUCT SUPPLY CHAIN</p> 	<p>EXCLUSIVITY OFFER A UNIQUE, HIGH-QUALITY SOLUTION TO YOUR CUSTOMERS</p> 	<p>SUSTAINABILITY BASED UPON 100% RECYCLABLE ALUMINUM, THE SYSTEM IS ENVIRONMENTALLY SUSTAINABLE</p> 
--	--	---	--	--

STANDARD PROCESSING SYSTEM OUTPUTS

MODERATE VOLUME		90 plates / day *
HIGH VOLUME		150 plates / day *
EXTREME VOLUME		300 plates / day *

* 12" x 20" plates

Each Metalphoto system is designed to fit your space and application. During the design process Metalphoto engineers will work with your team to build a system for your applications.

Horizons Incorporated
ISG Imaging Systems Group

18531 South Miles Road
Cleveland, OH 44128 USA

T: 1-800-482-7758
F: 216-475-6507

E: info@HorizonsISG.com
W: www.metalphoto.com

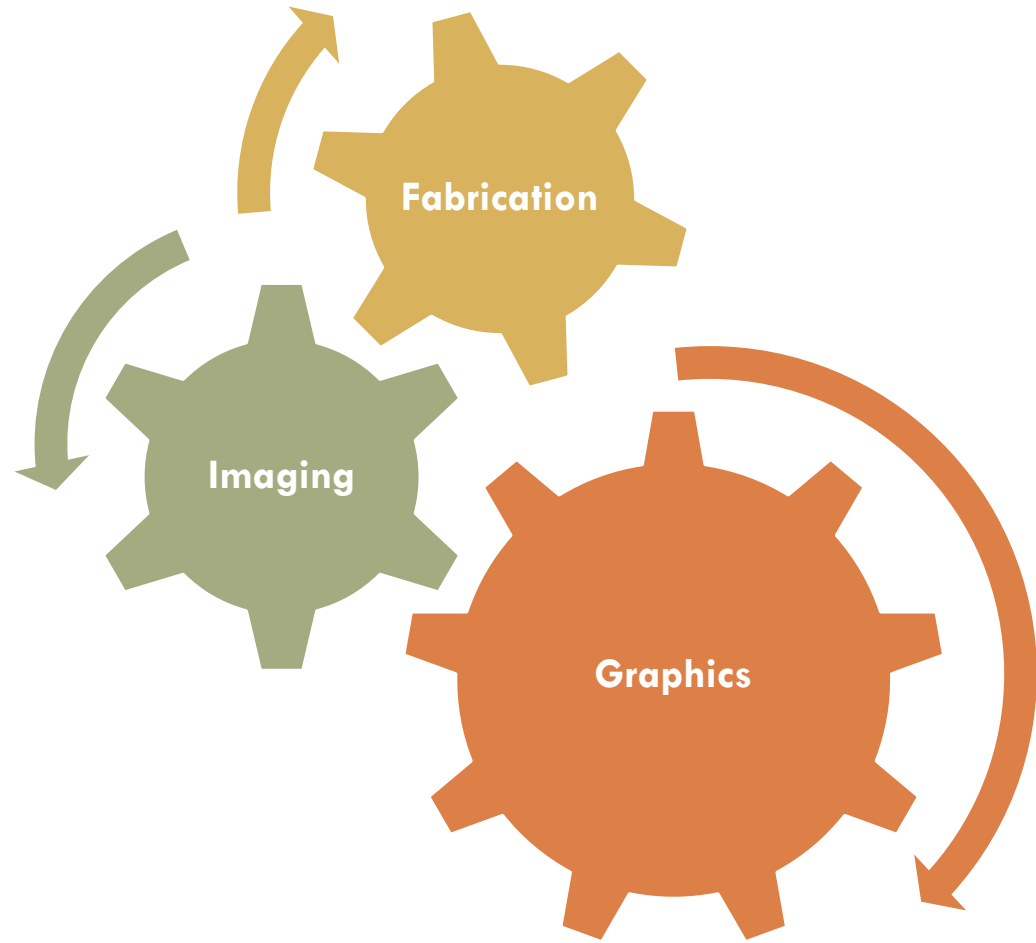

Make vs. Buy Sales Qualification (draft)

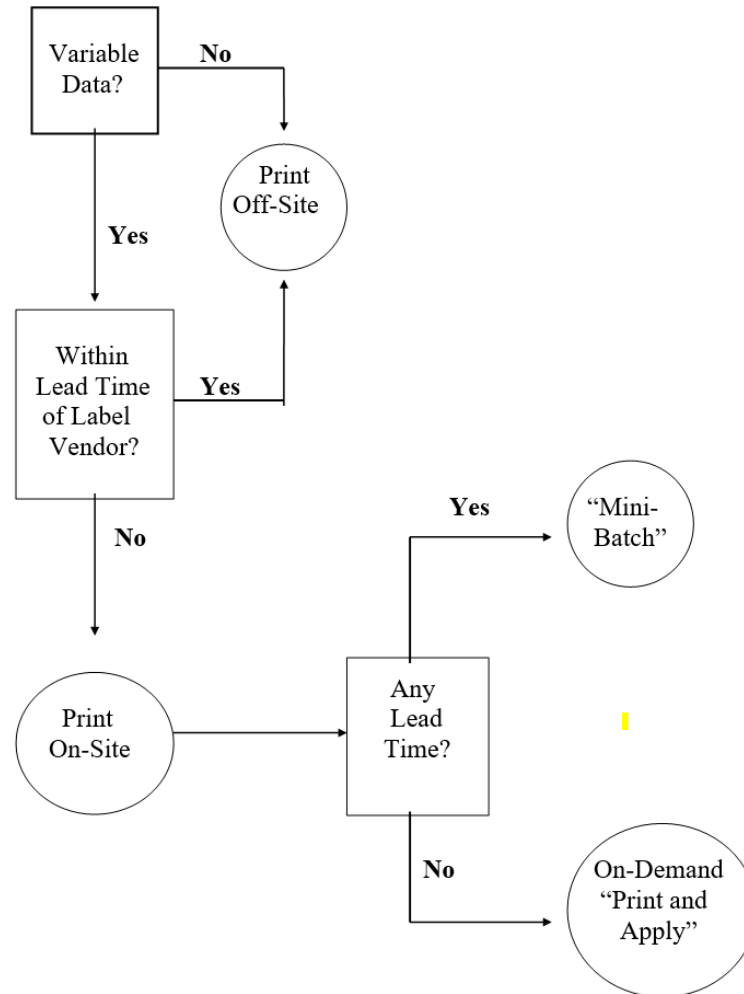

Metalphoto Fakes

- How to deal with cheaters.
 - Saying something is Metalphoto when it isn't.
 - Saying something meets a spec when it doesn't.
 - Mis using the Metalphoto[®] trademark.

Metalphoto Competitors ~ Dealing with Objections to Price or Pre-Print

- What's the cost of failure?
 - ▣ Avoidable downtime?
 - ▣ Avoidable lost revenue?
 - ▣ Someone get's hurt/killed due to inaccurate inspections/maintenance/asset ID?
 - ▣ Customer Service tanks?
- What's the cost of re-labelling/fixing cheap labels?
 - ▣ Labor cost to identify asset is significantly above that of the tag – visit asset once, tag forever.
- What's the value of your brand – product ID is your image.
- True cost of printing yourself...

Metalphoto for Equipment!



CATERPILLAR



Metalphoto for Transportation?



Metaphoto for Signage?

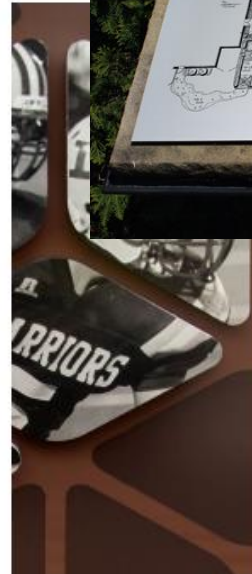



Tools to Sell...

selling tools @ www.metaphoto.com

Sell Sheets



metalphoto
Photo Anodized Aluminum

Exceptionally Durable. Widely Specified. Always Readable.

Product Benefits

- Longevity** - 20 year life expectancy
- Readability** - 100% readability
- Cost** - 1/3 the cost of other methods
- Environment** - 100% recyclable
- Application** - 100% application

When durability matters, choose Metalphoto.

Case Studies



metalphoto Case Study:
Seatrax Offshore Cranes

Seatrax, a leading offshore crane manufacturer, chose Metalphoto photosensitive anodized aluminum for extreme durability and fast turnaround on permanent labels and markings.

When Durability, Cost and Lead Time are Critical, Etched & Filled Titanium Steel Does Not Perform

For more than 20 years, Seatrax has manufactured offshore pedestal mounted cranes that operate in extremely harsh conditions. The cranes and their components must withstand sunlight degradation, salt spray corrosion, abrasion and hydraulic fluid exposure. The American Petroleum Institute (API) requires that all crane control operations and functions be clearly marked and easily visible by the operator. This meant all labels and markings must be readable after 20 years of usage and exposure to the environment. Finding a company and process that met the readability of identification marks, imparts safe operation, cost competitive objectives and lead to regulatory fines.

Many equipment manufacturers use etched and filled titanium steel for components, labels and markings on cranes. However, Seatrax found titanium steel to have several disadvantages: longer lead times, high lead times and limited availability.

When durability matters, choose Metalphoto.

Specifications/Certifications



Logos for: Department of Defense, Honeywell, Boeing, Lockheed Martin, U.S. Army, BFGoodrich, Sikorsky (A United Technologies Company), Underwriters Laboratories Inc., NASA, Department of the Navy, United States of America.

Industry Specific Applications

Durability Tests

TEST	DESCRIPTION	RESULTS
ASTM D1708	Hydrocarbon Fluid	100% readability
ASTM D1708	Alcohol and Hydrocarbon	100% readability
ASTM D1708	Acetic Acid	100% readability
ASTM D1708	Ammonia	100% readability
ASTM D1708	Hydrochloric Acid	100% readability
ASTM D1708	Sulfuric Acid	100% readability
ASTM D1708	Hydrofluoric Acid	100% readability
ASTM D1708	Phosphoric Acid	100% readability
ASTM D1708	Sodium Hydroxide	100% readability
ASTM D1708	Potassium Hydroxide	100% readability
ASTM D1708	Sulfur Dioxide	100% readability
ASTM D1708	Ozone	100% readability
ASTM D1708	Ultraviolet Light	100% readability
ASTM D1708	High Temperature	100% readability
ASTM D1708	Low Temperature	100% readability
ASTM D1708	Impact	100% readability
ASTM D1708	Scratch	100% readability
ASTM D1708	Abuse	100% readability
ASTM D1708	Chemical Resistance	100% readability
ASTM D1708	Environmental Resistance	100% readability
ASTM D1708	UV Radiation	100% readability
ASTM D1708	Moisture	100% readability
ASTM D1708	Salt Crystals	100% readability
ASTM D1708	Microbial Growth	100% readability
ASTM D1708	Flammability	100% readability
ASTM D1708	Electromagnetic Interference	100% readability
ASTM D1708	Static Discharge	100% readability
ASTM D1708	Acoustic Shock	100% readability
ASTM D1708	Vibration	100% readability
ASTM D1708	Shock	100% readability
ASTM D1708	Drop	100% readability
ASTM D1708	Compression	100% readability
ASTM D1708	Flexure	100% readability
ASTM D1708	Peel	100% readability
ASTM D1708	Adhesion	100% readability
ASTM D1708	Impact	100% readability
ASTM D1708	Scratch	100% readability
ASTM D1708	Abuse	100% readability
ASTM D1708	Chemical Resistance	100% readability
ASTM D1708	Environmental Resistance	100% readability
ASTM D1708	UV Radiation	100% readability
ASTM D1708	Moisture	100% readability
ASTM D1708	Salt Crystals	100% readability
ASTM D1708	Microbial Growth	100% readability
ASTM D1708	Flammability	100% readability
ASTM D1708	Electromagnetic Interference	100% readability
ASTM D1708	Static Discharge	100% readability
ASTM D1708	Acoustic Shock	100% readability
ASTM D1708	Vibration	100% readability
ASTM D1708	Shock	100% readability
ASTM D1708	Drop	100% readability
ASTM D1708	Compression	100% readability
ASTM D1708	Flexure	100% readability
ASTM D1708	Peel	100% readability
ASTM D1708	Adhesion	100% readability
ASTM D1708	Impact	100% readability
ASTM D1708	Scratch	100% readability
ASTM D1708	Abuse	100% readability
ASTM D1708	Chemical Resistance	100% readability
ASTM D1708	Environmental Resistance	100% readability
ASTM D1708	UV Radiation	100% readability
ASTM D1708	Moisture	100% readability
ASTM D1708	Salt Crystals	100% readability
ASTM D1708	Microbial Growth	100% readability
ASTM D1708	Flammability	100% readability
ASTM D1708	Electromagnetic Interference	100% readability
ASTM D1708	Static Discharge	100% readability
ASTM D1708	Acoustic Shock	100% readability
ASTM D1708	Vibration	100% readability
ASTM D1708	Shock	100% readability
ASTM D1708	Drop	100% readability
ASTM D1708	Compression	100% readability
ASTM D1708	Flexure	100% readability
ASTM D1708	Peel	100% readability
ASTM D1708	Adhesion	100% readability
ASTM D1708	Impact	100% readability
ASTM D1708	Scratch	100% readability
ASTM D1708	Abuse	100% readability
ASTM D1708	Chemical Resistance	100% readability
ASTM D1708	Environmental Resistance	100% readability
ASTM D1708	UV Radiation	100% readability
ASTM D1708	Moisture	100% readability
ASTM D1708	Salt Crystals	100% readability
ASTM D1708	Microbial Growth	100% readability
ASTM D1708	Flammability	100% readability
ASTM D1708	Electromagnetic Interference	100% readability
ASTM D1708	Static Discharge	100% readability
ASTM D1708	Acoustic Shock	100% readability
ASTM D1708	Vibration	100% readability
ASTM D1708	Shock	100% readability
ASTM D1708	Drop	100% readability
ASTM D1708	Compression	100% readability
ASTM D1708	Flexure	100% readability
ASTM D1708	Peel	100% readability
ASTM D1708	Adhesion	100% readability
ASTM D1708	Impact	100% readability
ASTM D1708	Scratch	100% readability
ASTM D1708	Abuse	100% readability
ASTM D1708	Chemical Resistance	100% readability
ASTM D1708	Environmental Resistance	100% readability
ASTM D1708	UV Radiation	100% readability
ASTM D1708	Moisture	100% readability
ASTM D1708	Salt Crystals	100% readability
ASTM D1708	Microbial Growth	100% readability
ASTM D1708	Flammability	100% readability
ASTM D1708	Electromagnetic Interference	100% readability
ASTM D1708	Static Discharge	100% readability
ASTM D1708	Acoustic Shock	100% readability
ASTM D1708	Vibration	100% readability
ASTM D1708	Shock	100% readability
ASTM D1708	Drop	100% readability
ASTM D1708	Compression	100% readability
ASTM D1708	Flexure	100% readability
ASTM D1708	Peel	100% readability
ASTM D1708	Adhesion	100% readability
ASTM D1708	Impact	100% readability
ASTM D1708	Scratch	100% readability
ASTM D1708	Abuse	100% readability
ASTM D1708	Chemical Resistance	100% readability
ASTM D1708	Environmental Resistance	100% readability
ASTM D1708	UV Radiation	100% readability
ASTM D1708	Moisture	100% readability
ASTM D1708	Salt Crystals	100% readability
ASTM D1708	Microbial Growth	100% readability
ASTM D1708	Flammability	100% readability
ASTM D1708	Electromagnetic Interference	100% readability
ASTM D1708	Static Discharge	100% readability
ASTM D1708	Acoustic Shock	100% readability
ASTM D1708	Vibration	100% readability
ASTM D1708	Shock	100% readability
ASTM D1708	Drop	100% readability
ASTM D1708	Compression	100% readability
ASTM D1708	Flexure	100% readability
ASTM D1708	Peel	100% readability
ASTM D1708	Adhesion	100% readability
ASTM D1708	Impact	100% readability
ASTM D1708	Scratch	100% readability
ASTM D1708	Abuse	100% readability
ASTM D1708	Chemical Resistance	100% readability
ASTM D1708	Environmental Resistance	100% readability
ASTM D1708	UV Radiation	100% readability
ASTM D1708	Moisture	100% readability
ASTM D1708	Salt Crystals	100% readability
ASTM D1708	Microbial Growth	100% readability
ASTM D1708	Flammability	100% readability
ASTM D1708	Electromagnetic Interference	100% readability
ASTM D1708	Static Discharge	100% readability
ASTM D1708	Acoustic Shock	100% readability
ASTM D1708	Vibration	100% readability
ASTM D1708	Shock	100% readability
ASTM D1708	Drop	100% readability
ASTM D1708	Compression	100% readability
ASTM D1708	Flexure	100% readability
ASTM D1708	Peel	100% readability
ASTM D1708	Adhesion	100% readability
ASTM D1708	Impact	100% readability
ASTM D1708	Scratch	100% readability
ASTM D1708	Abuse	100% readability
ASTM D1708	Chemical Resistance	100% readability
ASTM D1708	Environmental Resistance	100% readability
ASTM D1708	UV Radiation	100% readability
ASTM D1708	Moisture	100% readability
ASTM D1708	Salt Crystals	100% readability
ASTM D1708	Microbial Growth	100% readability
ASTM D1708	Flammability	100% readability
ASTM D1708	Electromagnetic Interference	100% readability
ASTM D1708	Static Discharge	100% readability
ASTM D1708	Acoustic Shock	100% readability
ASTM D1708	Vibration	100% readability
ASTM D1708	Shock	100% readability
ASTM D1708	Drop	100% readability
ASTM D1708	Compression	100% readability
ASTM D1708	Flexure	100% readability
ASTM D1708	Peel	100% readability
ASTM D1708	Adhesion	100% readability
ASTM D1708	Impact	100% readability
ASTM D1708	Scratch	100% readability
ASTM D1708	Abuse	100% readability
ASTM D1708	Chemical Resistance	100% readability
ASTM D1708	Environmental Resistance	100% readability
ASTM D1708	UV Radiation	100% readability
ASTM D1708	Moisture	100% readability
ASTM D1708	Salt Crystals	100% readability
ASTM D1708	Microbial Growth	100% readability
ASTM D1708	Flammability	100% readability
ASTM D1708	Electromagnetic Interference	100% readability
ASTM D1708	Static Discharge	100% readability
ASTM D1708	Acoustic Shock	100% readability
ASTM D1708	Vibration	100% readability
ASTM D1708	Shock	100% readability
ASTM D1708	Drop	100% readability
ASTM D1708	Compression	100% readability
ASTM D1708	Flexure	100% readability
ASTM D1708	Peel	100% readability
ASTM D1708	Adhesion	100% readability
ASTM D1708	Impact	100% readability
ASTM D1708	Scratch	100% readability
ASTM D1708	Abuse	100% readability
ASTM D1708	Chemical Resistance	100% readability
ASTM D1708	Environmental Resistance	100% readability
ASTM D1708	UV Radiation	100% readability
ASTM D1708	Moisture	100% readability
ASTM D1708	Salt Crystals	100% readability
ASTM D1708	Microbial Growth	100% readability
ASTM D1708	Flammability	100% readability
ASTM D1708	Electromagnetic Interference	100% readability
ASTM D1708	Static Discharge	100% readability
ASTM D1708	Acoustic Shock	100% readability
ASTM D1708	Vibration	100% readability
ASTM D1708	Shock	100% readability
ASTM D1708	Drop	100% readability
ASTM D1708	Compression	100% readability
ASTM D1708	Flexure	100% readability
ASTM D1708	Peel	100% readability
ASTM D1708	Adhesion	100% readability
ASTM D1708	Impact	100% readability
ASTM D1708	Scratch	100% readability
ASTM D1708	Abuse	100% readability
ASTM D1708	Chemical Resistance	100% readability
ASTM D1708	Environmental Resistance	100% readability
ASTM D1708	UV Radiation	100% readability
ASTM D1708	Moisture	100% readability
ASTM D1708	Salt Crystals	100% readability
ASTM D1708	Microbial Growth	100% readability
ASTM D1708	Flammability	100% readability
ASTM D1708	Electromagnetic Interference	100% readability
ASTM D1708	Static Discharge	100% readability
ASTM D1708	Acoustic Shock	100% readability
ASTM D1708	Vibration	100% readability
ASTM D1708	Shock	100% readability
ASTM D1708	Drop	100% readability
ASTM D1708	Compression	100% readability
ASTM D1708	Flexure	100% readability
ASTM D1708	Peel	100% readability
ASTM D1708	Adhesion	100% readability
ASTM D1708	Impact	100% readability
ASTM D1708	Scratch	100% readability
ASTM D1708	Abuse	100% readability
ASTM D1708	Chemical Resistance	100% readability
ASTM D1708	Environmental Resistance	100% readability
ASTM D1708	UV Radiation	100% readability
ASTM D1708	Moisture	100% readability
ASTM D1708	Salt Crystals	100% readability
ASTM D1708	Microbial Growth	100% readability
ASTM D1708	Flammability	100% readability
ASTM D1708	Electromagnetic Interference	100% readability
ASTM D1708	Static Discharge	100% readability
ASTM D1708	Acoustic Shock	100% readability
ASTM D1708	Vibration	100% readability
ASTM D1708	Shock	100% readability
ASTM D1708	Drop	100% readability
ASTM D1708	Compression	100% readability
ASTM D1708	Flexure	100% readability
ASTM D1708	Peel	100% readability
ASTM D1708	Adhesion	100% readability
ASTM D1708	Impact	100% readability
ASTM D1708	Scratch	100% readability
ASTM D1708	Abuse	100% readability
ASTM D1708	Chemical Resistance	100% readability
ASTM D1708	Environmental Resistance	100% readability
ASTM D1708	UV Radiation	100% readability
ASTM D1708	Moisture	100% readability
ASTM D1708	Salt Crystals	100% readability
ASTM D1708	Microbial Growth	100% readability
ASTM D1708	Flammability	100% readability
ASTM D1708	Electromagnetic Interference	100% readability
ASTM D1708	Static Discharge	100% readability
ASTM D1708	Acoustic Shock	100% readability
ASTM D1708	Vibration	100% readability
ASTM D1708	Shock	100% readability
ASTM D1708	Drop	100% readability
ASTM D1708	Compression	100% readability
ASTM D1708	Flexure	100% readability
ASTM D1708	Peel	100% readability
ASTM D1708	Adhesion	100% readability
ASTM D1708	Impact	100% readability
ASTM D1708	Scratch	100% readability
ASTM D1708	Abuse	100% readability
ASTM D1708	Chemical Resistance	100% readability
ASTM D1708	Environmental Resistance	100% readability
ASTM D1708	UV Radiation	100% readability
ASTM D1708	Moisture	100% readability
ASTM D1708	Salt Crystals	100% readability
ASTM D1708	Microbial Growth	100% readability
ASTM D1708	Flammability	100% readability
ASTM D1708	Electromagnetic Interference	100% readability
ASTM D1708	Static Discharge	100% readability
ASTM D1708	Acoustic Shock	

Technical Specifications

MATERIAL: Anodized Aluminum Sheets

SIZES: 10" x 12", 12" x 20", 20" x 24", 20" x 40", 24" x 40"

THICKNESSES: .003", .005", .008", .012", .020", .032", .039", .063", .090", .125"

FINISHES:



MATTE

non-reflective
with dull finish



SATIN

semi-gloss medium
reflective material



4

brushed to resemble
a stainless steel finish



GLOSS

highly reflective,
mirror-like

□ **More @ <http://metalphoto.com/#resources>**

Videos



Demo Power!!!



Metalphoto Performance



Metalphoto Durability

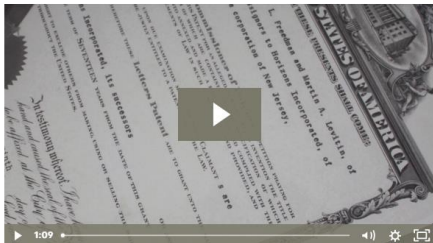

Metalphoto Image Resolution



Metalphoto Variable Information Capability

- [Will It Read Destructive Testing PowerPoint](#)
- [Will It Read Testing Video \(Abrasion\)](#)
- [Will It Read Testing Video \(High Temp\)](#)
- [Will It Read Testing Video \(Saltwater\)](#)
- [Will It Read Testing Video \(Chemical Exposure\)](#)

Questions?

www.metalphoto.com

metalphoto[®]

Cross-section

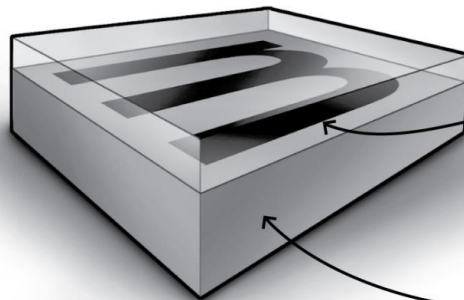

anodic layer

the glass-clear, sapphire-hard anodized layer resists chemicals, paint, abrasion and dirt.

sealed image

black graphics are metallic silver particles that hold up to extreme heat and sunlight exposure.

aluminum layer

the rigid aluminum base will not peel, crack or delaminate.